

F/G-20 Series

Up to 1.0 gpm (3.8 l/min)

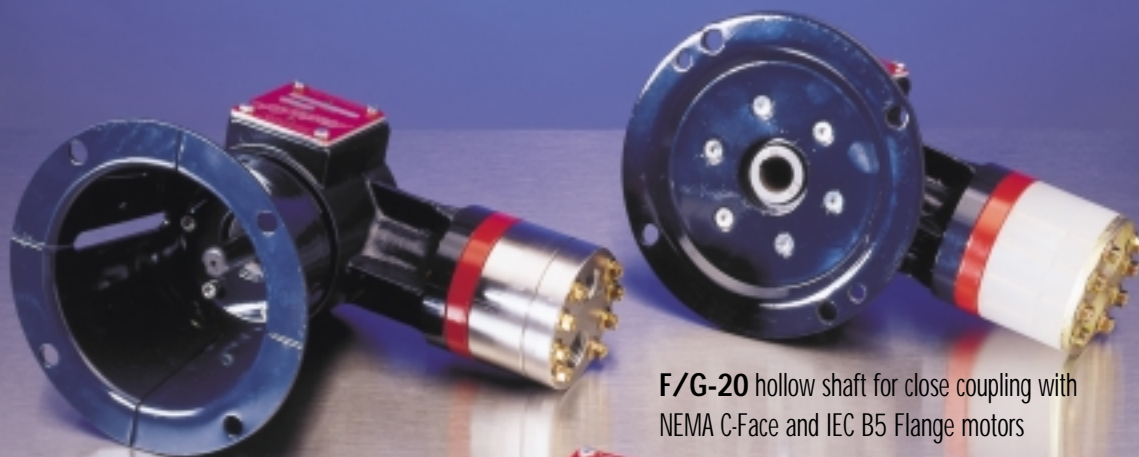

F/G-20 hollow shaft for close coupling with NEMA C-Face and IEC B5 Flange motors

F/G-22 with Pump/Motor Adapter for coupling to NEMA C-Face and IEC B5 Flange motors

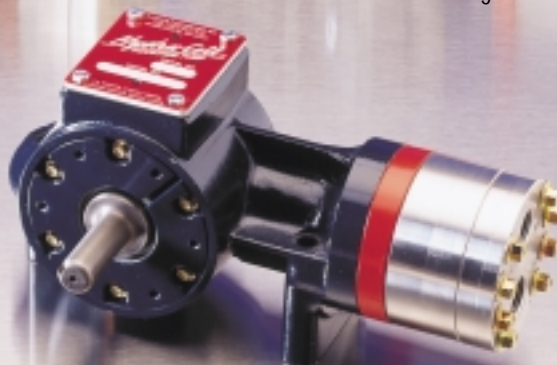

F/G-21 shaft-driven

Hydra-Cell[®]
SIMPLY BUILT TO LAST

F/G-20 Series Performance

flow

| model* | max flow | | max input rpm |
|----------|----------|-------|---------------|
| | gpm | l/min | |
| F/G-20-X | 0.96 | 3.63 | 1750 |
| F/G-20-E | 0.73 | 2.76 | 1750 |
| F/G-20-S | 0.55 | 2.08 | 1750 |
| F/G-20-B | 0.33 | 1.25 | 1750 |
| F/G-20-G | 0.20 | 0.76 | 1750 |

pressure

Maximum Inlet Pressure:

100 psi (7 bar)

Maximum Pressure:

Metallic Pump Heads:

F/G-20: 1000 psi (70 bar)

F/G-21: 1500 psi (100 bar)

F/G-22: 1500 psi (100 bar)

Non-Metallic Pump Heads:

All Models: 250 psi (17 bar)

* Note

Performance and specification ratings apply to all configurations unless specifically noted otherwise.

Calculating Required Horsepower (kW)**

$$\frac{2 \times \text{rpm}}{63,000} + \frac{\text{gpm} \times \text{psi}}{1,460} = \text{electric motor HP}$$

$$\frac{2 \times \text{rpm}}{84,428} + \frac{\text{lpm} \times \text{bar}}{511} = \text{electric motor kW}$$

**rpm equals pump shaft rpm. HP/kW is required application power. Use caution when sizing motors with variable speed drives.

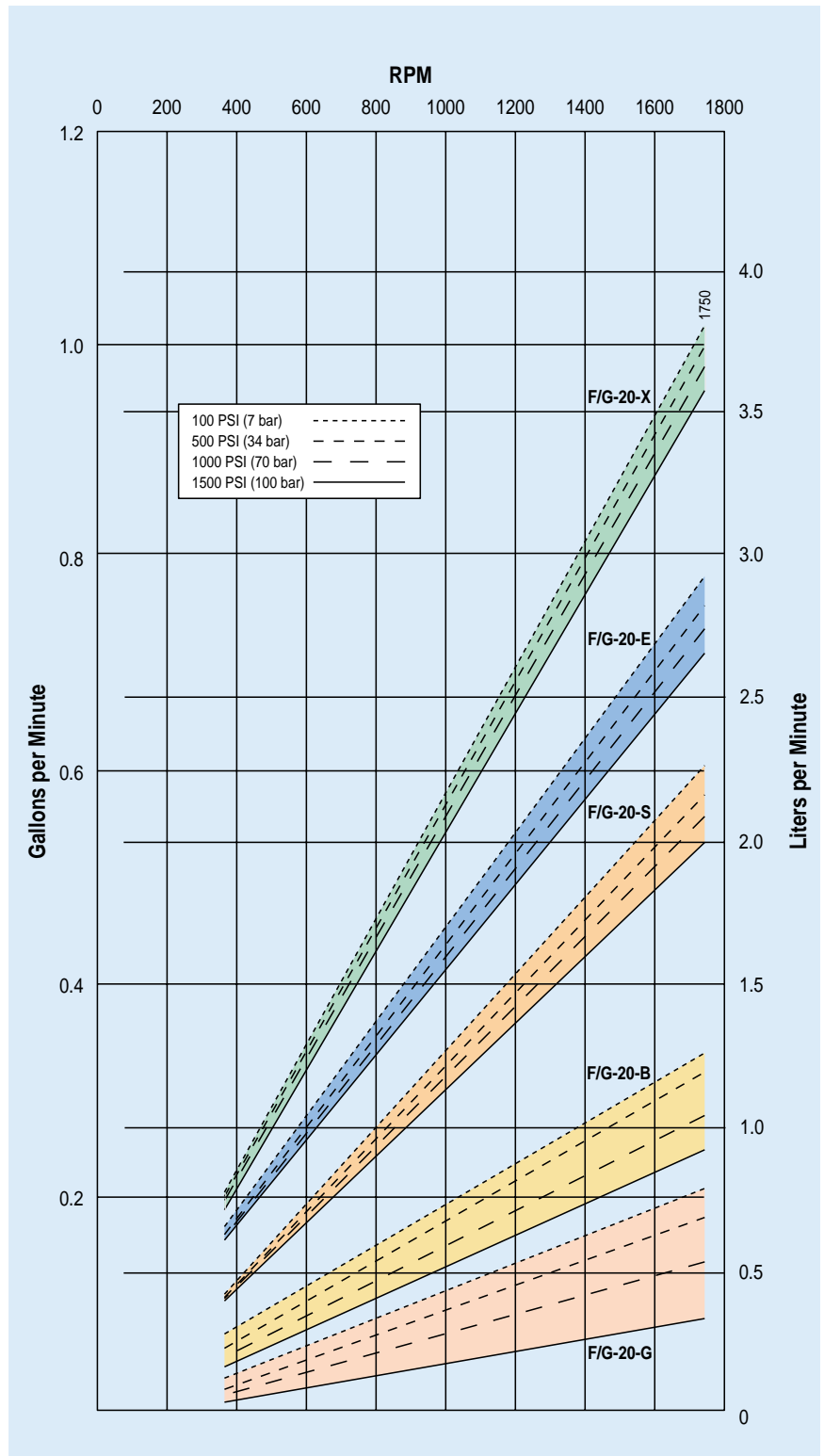

F/G-20 Series Specifications

Max Pressure*

| | |
|---------------------|---|
| Metallic Heads: | F/G-20: 1000 psi (70 bar); F/G-21 & F/G-22: 1500 psi (100 bar) |
| Non-Metallic Heads: | All Models: 250 psi (17 bar) |

Capacity @ Max Pressure*

| | rpm | gpm | l/min |
|----------|------|------|-------|
| F/G-20-X | 1750 | 0.96 | 3.63 |
| F/G-20-E | 1750 | 0.73 | 2.76 |
| F/G-20-S | 1750 | 0.55 | 2.08 |
| F/G-20-B | 1750 | 0.33 | 1.25 |
| F/G-20-G | 1750 | 0.20 | 0.76 |

Delivery @ Max Pressure*

| | revs/gal | revs/liter |
|----------|----------|------------|
| F/G-20-X | 1823 | 500 |
| F/G-20-E | 2397 | 659 |
| F/G-20-S | 3182 | 906 |
| F/G-20-B | 5303 | 1400 |
| F/G-20-G | 8750 | 2302 |

Max Inlet Pressure 100 psi (7 bar)

Max Temperature

| | |
|---------------------|---|
| Metallic Heads: | 250°F (121°C) – Consult factory for correct component selection for temperatures above 160°F (71°C) |
| Non-Metallic Heads: | 140°F (60°C) |

Inlet Port F-20/21/22: 1/2 inch NPT
G-20/21/22: 1/2 inch BSPT

Discharge Port F-20/21/22: 3/8 inch NPT
G-20/21/22: 3/8 inch BSPT

Shaft Diameter F-20: 5/8 inch hollow shaft for NEMA 56C C-Face motor (with feet)
F-21: 5/8 inch shaft driven*
F-22: 5/8 inch*
G-20: 19 mm for IEC 80 B5 Flange motor (with feet)
G-21: 19 mm shaft driven*
G-22: 19 mm shaft driven*
*Refer to Pump/Motor Adapter section

Shaft Rotation Bi-directional

Bearings Ball bearings

Oil Capacity 1/8 US quart (0.12 liters), see Accessories Section for oil selection and specification.

Weight

| | |
|---------------------|-----------------|
| Metallic Heads: | 12 lbs (5.5 kg) |
| Non-Metallic Heads: | 9 lbs (4.1 kg) |

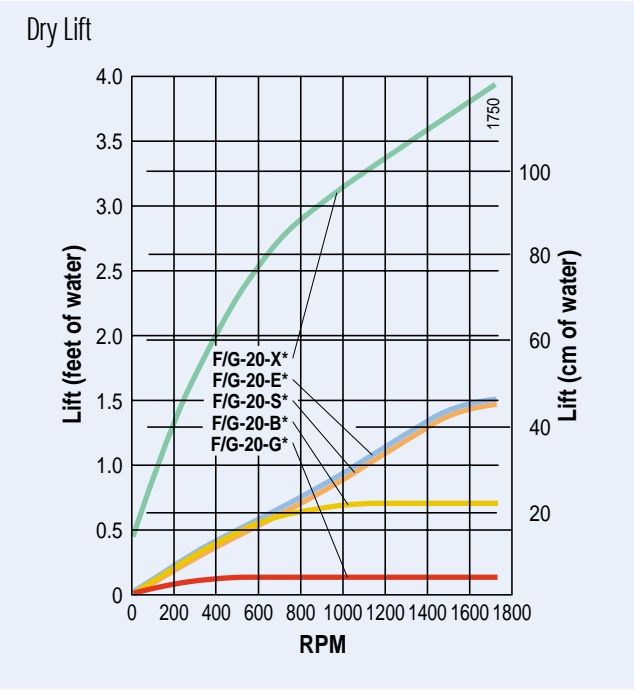
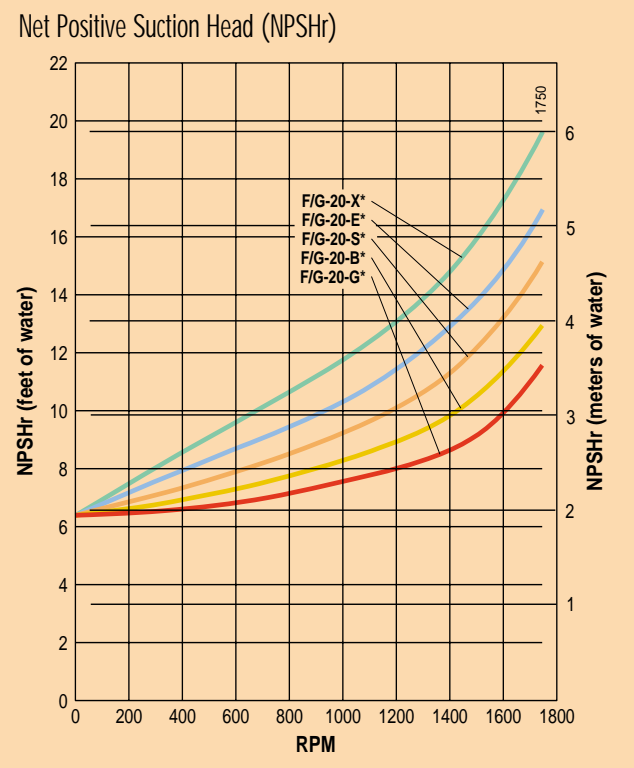

* Note

Performance and specification ratings apply to all configurations unless specifically noted otherwise.

Refer to installation guidelines and design considerations section for additional information.

F/G-20 Series Dimensions

F/G-20 Models with Metallic Pumping Head

Brass
316 Stainless Steel
Hastelloy® C

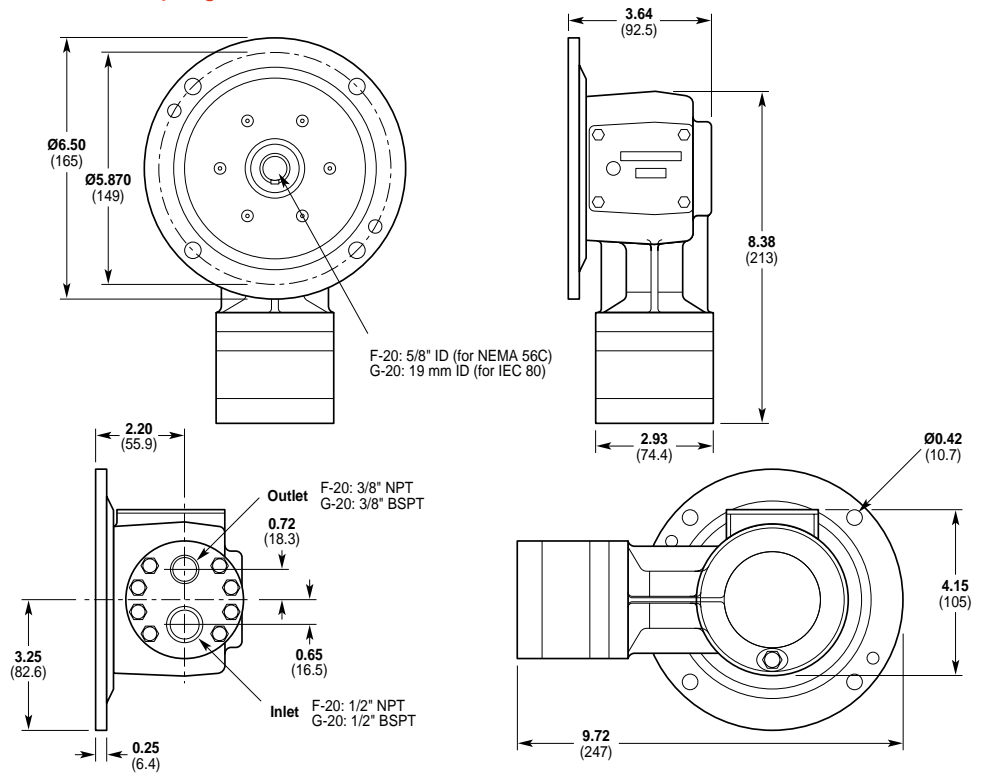

F/G-20 Models with Non-metallic Pump Head

Kynar®
Polypropylene

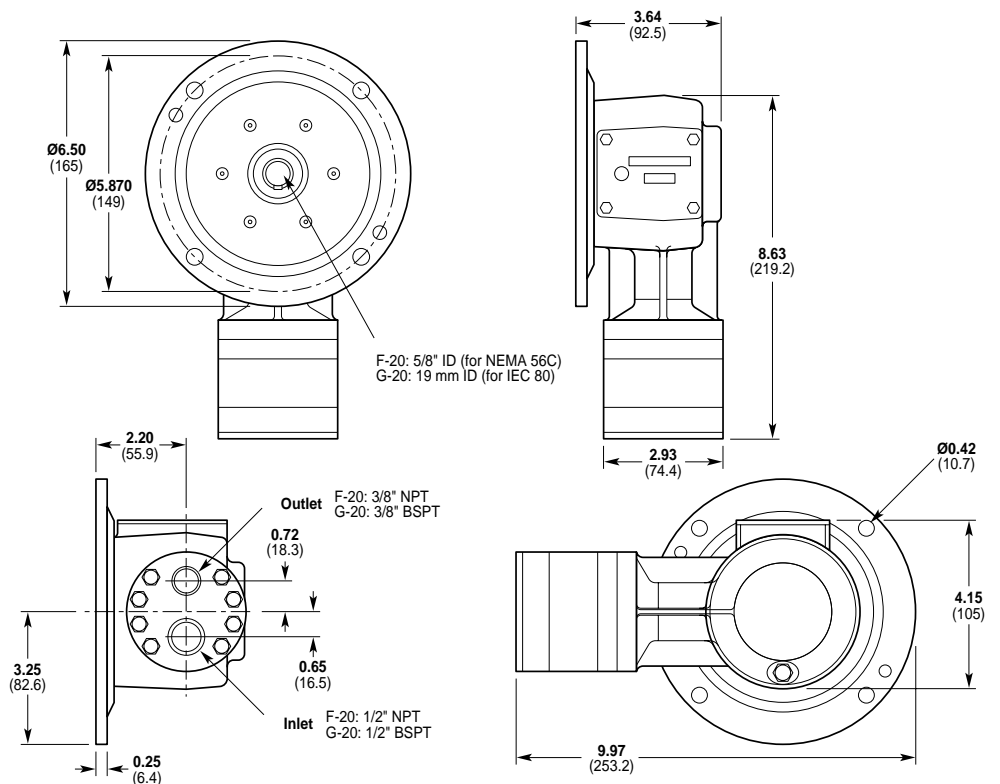

F/G-20 Series Dimensions

F/G-21 Models with Metallic Pumping Head

Brass
316 Stainless Steel
Hastelloy® C

– Note

F/G-21 Pump/Motor Adapter flange ordered separately (see page 32)

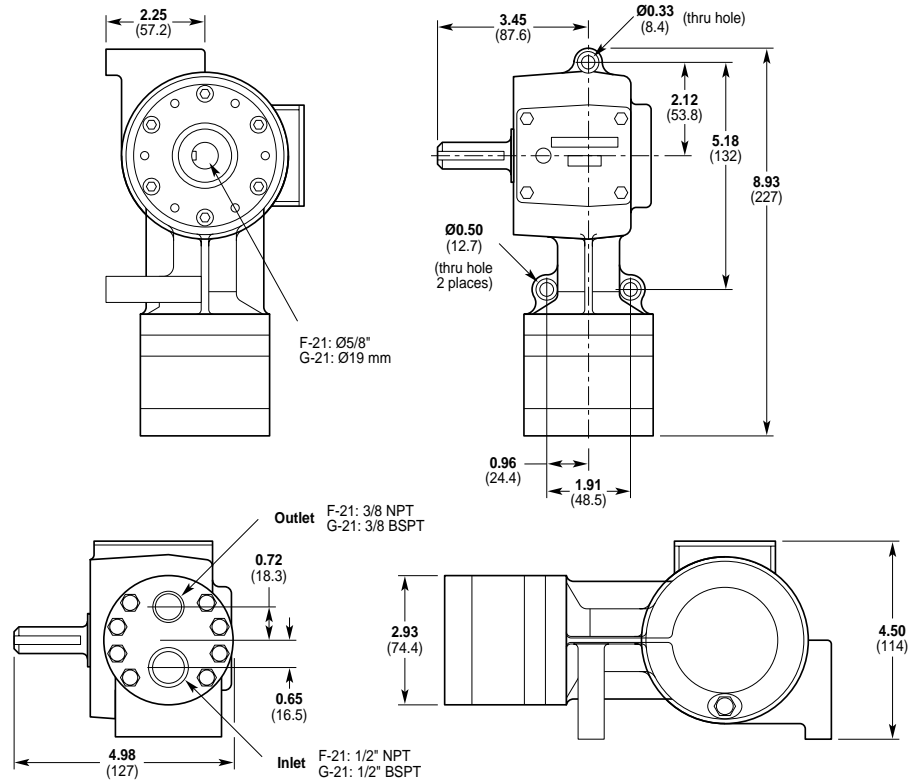

F/G-21 Models with Non-metallic Pump Head

Kynar®
Polypropylene

– Note

F/G-21 Pump/Motor Adapter flange ordered separately (see page 32)

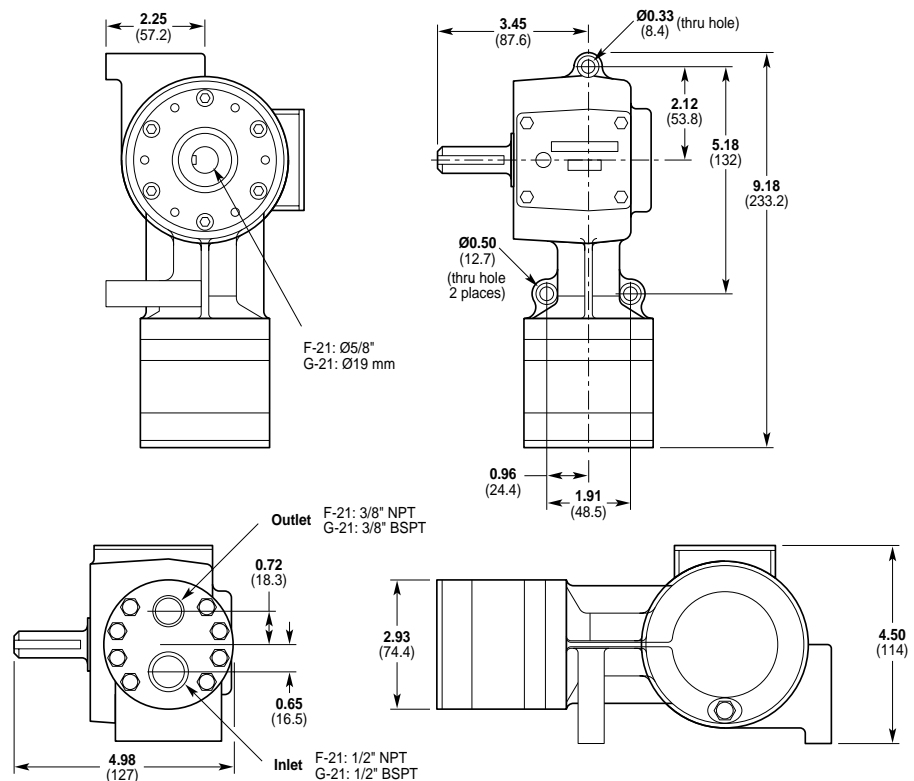

F/G-20 Series Dimensions

F/G-22 Models with Metallic Pumping Head

Brass
316 Stainless Steel
Hastelloy® C

– Note
F/G-21 Pump/Motor Adapter
flange ordered separately
(see page 32)

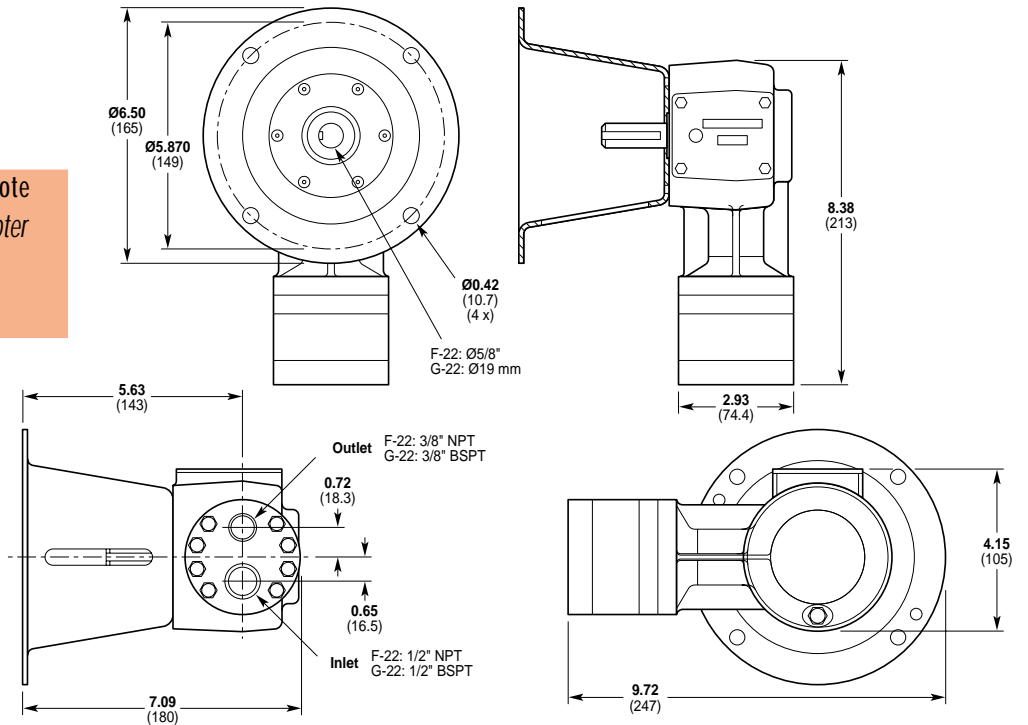

F/G-22 Models with Non-metallic Pump Head

Kynar®
Polypropylene

– Note
F/G-21 Pump/Motor Adapter
flange ordered separately
(see page 32)

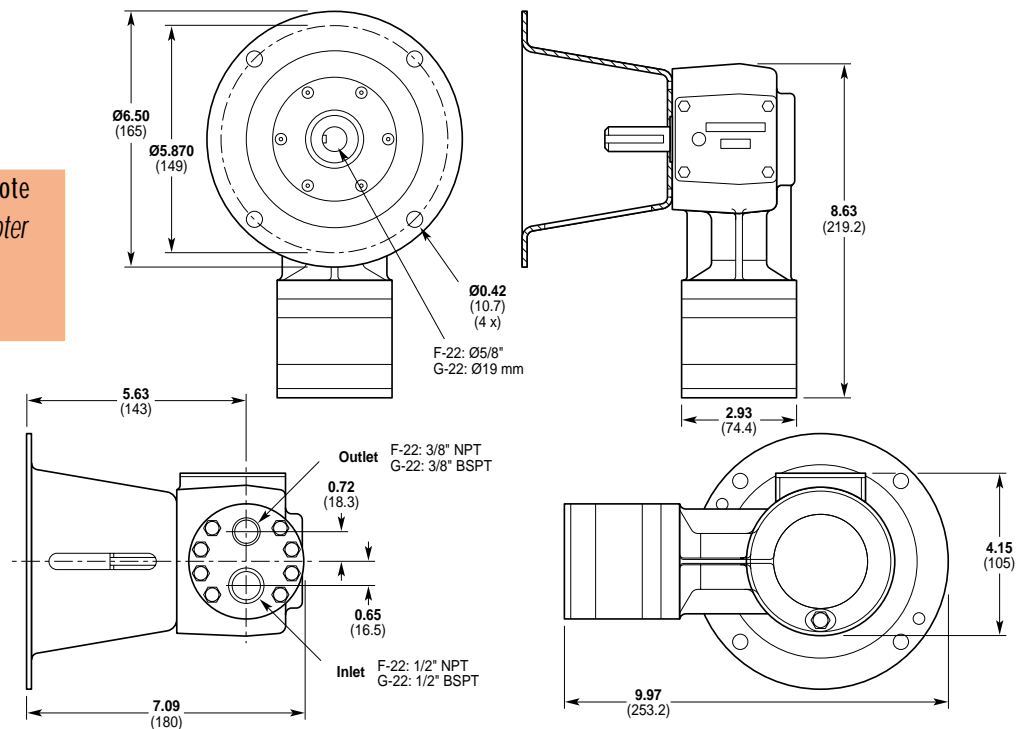

F/G-20 Series Options

Materials of Construction

Hydra-Cell pumps are manufactured in a variety of heavy-duty materials to meet specific pumping needs. Refer to the design section for more information on appropriate material selection and chemical compatibility. Other customized materials are available by special order. Contact factory application engineering department for further information.

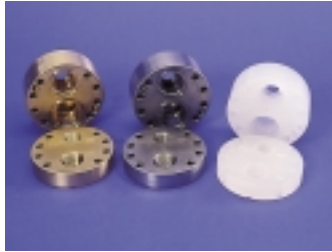

Pumping Head

316 Stainless Steel
Brass
Kynar®
Hastelloy® C
Polypropylene



Valves

17-7 PH Stainless Steel
Ceramic
Hastelloy® C
Nitronic 50
Tungsten Carbide



Diaphragms & O-rings

Buna-N-XS
EPDM
Neoprene
Teflon®
Viton®-XT

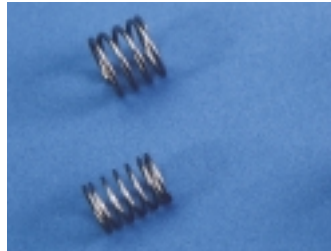

Valve Springs

Elgiloy®
Hastelloy® C



Valve Seats

17-4 PH Stainless Steel
316 Stainless Steel
Ceramic
Hastelloy® C
Tungsten Carbide



Valve Spring Retainers

Celcon®
Kynar®
Nylon
Polypropylene
17-7 PH Stainless Steel
Hastelloy® C

F/G-20 Series Accessories

Options, Accessories and Custom Designs

See the Accessories Section for complete information on these other products:

- Valves
- Couplings
- Hose Connectors
- Hydra-Oil
- Oil Cooler and Filtering System
- Oil Reservoir
- Tool Kits
- Pump/Motor Adapters



Pump/Motor Adapter

(Ordered separately)

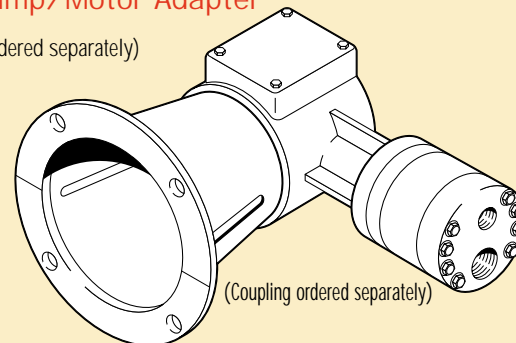

(Coupling ordered separately)

Part Number: A04-005-1200

For F-21/22 for use with NEMA 56C, 143/145TC C-Face motors.

Part Number: A04-006-1200

For G-21/22 for use with IEC 80-90 B5 Flange motors.

See the Accessories Section for dimensions.

F/G-20 Series How To Order

Ordering Information

A complete F/G-20 Series Model Number contains 12 digits including 9 customer-specified design options: for example F20XABGSNEPG



| Digit | Order Code | Description |
|------------|--|--|
| 1-3 | Pump Configuration | |
| | F20 | Close-coupled to NEMA 56C (NPT ports) |
| | F21 | Shaft-driven (NPT ports) |
| | F22 | For use with pump/motor adapter (NPT ports) |
| | G20 | Close-coupled to IEC 80 (BSPT ports) |
| | G21 | Shaft-driven (BSPT ports) |
| 4 | Hydraulic End Cam | |
| | X | Max 0.96 gpm (3.79 lpm) @ 1750 rpm |
| | E | Max 0.73 gpm (2.76 lpm) @ 1750 rpm |
| | S | Max 0.55 gpm (2.08 lpm) @ 1750 rpm |
| | B* | Max 0.33 gpm (1.25 lpm) @ 1750 rpm |
| | G* | Max 0.20 gpm (0.76 lpm) @ 1750 rpm |
| 5 | Pump Head Version | |
| | A | Version A Pump Head (NPT ports) |
| 6 | Pump Head Material | |
| | B | Brass |
| | M | Kynar® |
| | P | Polypropylene |
| | S | 316 Stainless Steel |
| | T | Hastelloy® C |
| 7 | Diaphragm & O-ring Material | |
| | E | EPDM (requires EPDM-compatible oil – Digit 12 oil code J) |
| | G | Viton®-XT |
| | J* | Teflon® (available with X and E cams only; cannot be used with non-metallic heads) |
| | P | Neoprene |
| 8 | Valve Seat Material | |
| | C | Ceramic |
| | D | Tungsten Carbide |
| | H | 17-4 PH Stainless Steel |
| | S | 316 Stainless Steel |
| 9 | Valve Material | |
| | C | Ceramic |
| | D | Tungsten Carbide |
| | H | 17-7 PH Stainless Steel |
| | T | Hastelloy® C |

| Digit | Order Code | Description |
|-----------|-------------------------------|---|
| 10 | Valve Springs | |
| | E | Elgiloy® |
| 11 | T | Hastelloy® C |
| | Valve Spring Retainers | |
| | C | Celcon |
| | H | 17-7 PH Stainless Steel |
| | M | Kynar® |
| 12 | P | Polypropylene |
| | T | Hastelloy® C |
| | Y | Nylon |
| | Hydra-Oil | |
| | G | 5W30 standard & cold-temp severe duty oil |
| J | 20-wt EPDM-compatible oil | |
| K | 20-wt food-contact oil | |

Replacement Hydraulic End Assembly

Complete F/G-20 Hydraulic End Assemblies are available as replacement items. The Hydraulic End contains all drive end components from the drive shaft up to and including the diaphragms. All Hydraulic Ends are factory tested and shipped with oil. To order a Replacement Hydraulic End, specify the desired Cam (Digit 4), the Diaphragm and O-ring Material (Digit 7), and the Hydra-Oil (Digit 12).

Part Number*

| | | | | | | | | | | | |
|-----|-----------|-----------|-----------|-------------|------------|-----|-----------|-----------|-----------|-------------|------------|
| F20 | <u>4*</u> | <u>XX</u> | <u>7*</u> | <u>XXXX</u> | <u>12*</u> | G20 | <u>4*</u> | <u>XX</u> | <u>7*</u> | <u>XXXX</u> | <u>12*</u> |
| F21 | <u>4*</u> | <u>XX</u> | <u>7*</u> | <u>XXXX</u> | <u>12*</u> | G21 | <u>4*</u> | <u>XX</u> | <u>7*</u> | <u>XXXX</u> | <u>12*</u> |
| F22 | <u>4*</u> | <u>XX</u> | <u>7*</u> | <u>XXXX</u> | <u>12*</u> | G22 | <u>4*</u> | <u>XX</u> | <u>7*</u> | <u>XXXX</u> | <u>12*</u> |

* Order Code Digits 4, 7 and 12 must be filled in when ordering.

* May require pressurized inlet.